

# ***USER'S MANUAL***

**KEEP THE MANUAL NEAR THE MACHINE ALL TIME  
AND MAKE SURE ALL USERS HAVE READ THIS**



**BTD CARTOOLS**

**ITEM NO: BTD J3.6**

**FOLLOW THE INSTRUCTIONS CAREFULLY TO GRANT THE  
MACHINE A CORRECT FUNCTION AND LONG SERVICE LIFE.**

## CONTENTS

<b>Manufacturer and service agent.....</b>	
<b>Packing, transport and storage.....</b>	
<b>introduction.....</b>	
<b>Chapter 1 Description of the machine.....</b>	
<b>Chapter 2 Technical specifications.....</b>	
<b>Chapter 3 Safety.....</b>	
<b>Chapter 4 Installation.....</b>	
<b>Chapter 5 Adjusting.....</b>	
<b>Chapter 6 Operating principles and use.....</b>	
<b>Chapter 7 Troubleshooting.....</b>	
<b>Chapter 8 Appendix .....</b>	



All packing, lifting, handling, transport and unpacking operations are to be performed exclusively by expert personnel

**PACKING AND TRANSPORT**

**Packing : (Picture 1)**

**Standard equipment:** oil line and accessory (1# BOX) , main and sub beam (3#、4# BOX) , control box (2# BOX) , font and back stop board (5# BOX) , standard equipment, total is 5 pieces.

**Choosing equipment:** leading board (6# BOX) , cover (7# BOX) 1 piece, (use to installation)

**PACKING LIST**

Number	Name	Accessory name and number
1	Oil line and accessory	1. M16 anchor bolts 16 suits; M18 anchor bolts 4 suits; 2. 6*4mm air line 2 suits; 8*5mm air line 3 suits; 3. 1.5mm line 5 m. 4.metal pipe 6 m 5. limit switch and line 2 suits 6. 1 set of user's manual 7. user's manual 8. seal 9. 10 line 10. high pressure oil line 9 piece. 11. 12. 13.
2	Control cabinet(EX)	
3	Main beam (1p)	1. M16 anchor bolts 16 suits; adjust shim 2. 3.
4	Sub beam (2p)	
5	Front and back stop board	1. Front stop board 2 pieces 2. back stop board 2 pieces
6	Leading board	2 pieces
7	cover	1 piece of 1000mm, 1 piece of 950mm, 1 piece of 750mm
	data	

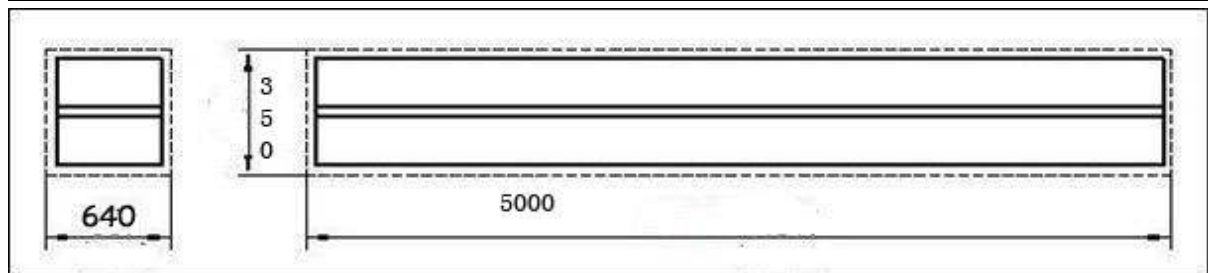

picture 1

**Transport:** (picture 2)



**Packing can be lifted or moved by lift trucks, cranes or bridge cranes.**

**In case of slinging, a second person must always take care of the load, in order to avoid dangerous oscillations.**

At the arrival of the goods, check for possible damage due to transport operations. Also verify that all items specified in the delivery notes are included. In case of missing parts, possible defects or damage due to transport operations. Also verify that all items specified in the delivery notes are included. In case of missing parts, possible defects or damage due to transport, the person in charge or the carrier must be immediately informed.



**Furthermore, during loading and unloading operation goods must be handle as shown in the picture.**

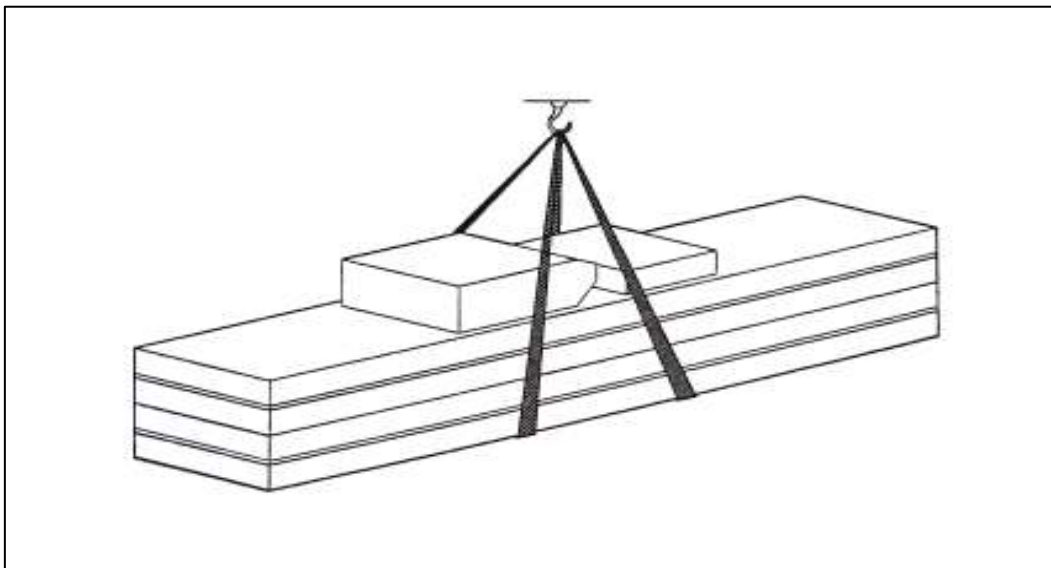

(picture 2)

### **STORAGE:**

Equipment should store in warehouse, waterproof process should do in outdoor.

Adopt Cabinet truck during transportation, cabinet storage in shipping.

Control box should store in vertical, and be careful of compressing.

Storage temperature: -25°C~55°C



**This manual has been prepared for workshop personnel expert in the use of the lift (operator) and technicians responsible for routine maintenance ( maintenance fitter); read the manual before carrying out any operation with the lift and/or the packing. This manual contains important information regarding:**

- the personal safety of operators and maintenance workers.
- Lift safety,
- The safety of lifted vehicles



#### **Conserving the manual**

This manual is an integral part of the lift, which it should always accompany, even if the unit is sold.

The manual must be kept in the vicinity of the lift, in an easily accessible place.

The operator and maintenance staff must be able to locate and consult the manual quickly and at any time.

Attentive and repeated reading of chapter 3, which contains important information and safety warning, is particularly recommended.



**The lifting, transport, unpacking, assembly, installation, starting up, initial adjustment and testing, extraordinary maintenance, repair, overhauls, transport and dismantling of the lift must be performed by specialized personnel from the licensed dealer or an service center authorized by the manufacturer.**

The manufacturer declines all responsibility for injury to persons or damage to vehicles or objects when any of the above mentioned operations has been performed by unauthorized personnel or when the rack has been subject to improper use.



**This manual indicates only the operative and safety aspects that may prove useful to the operator and maintenance worker, I better understanding the structure and operation of the lift and for best use of the same.**

In order to understand the terminology used in this manual, the maintenance and repair activities, the ability to interpret correctly the drawings and descriptions contained in the manual and be the country in which the machine has been installed.

The same applies to the maintenance fitter, who must also possess specific and specialized knowledge (mechanical, engineering) needed to perform the operations described in the manual in complete safety.

The words “operator” and “maintenance fitter” used in this manual are construed as follows:

- OPERATOR: person authorized to use the lift
- MAINTENANCE FITTER: person authorized for routine maintenance of the lift.



**NOTE: Manufacturer own the right to make little change for the manual**

## Chapter 1 DESCRIPTION OF THE MACHINE

**MACHINE**

BTD J3.6 scissor lift suitable for use in four wheel alignment, vehicle tests, maintenance and care for various types of small automobiles.

**Features:**

- imported electric components from Taiwan and Italy
- Graceful outlook, with concealing structure for the two levels and superior synchronization.
- Easy for tyre mount and dismount and chassis maintenance.
- the position of the front wheel turntable (optional part) is movable so that the side slide plate can be fit for more cars.
- the pneumatic double-teeth self-locking system and the anti explosive pipe insurance are automatic opening when lowering. The sliding block is made by oil and super-friction materials.
- stable and reliable equipment is relayed on imported hydraulic, pneumatic and electrical components.

**Equipment:**

- machine basement
- machine frame
- control box

**Frame:**

Make up for steel connecting rod, main lifting platform, sliding board, pneumatic double tooth, hydraulic oil tank.

**Control box**

under the control box is hydraulic oil tank and hydraulic pump, valve and other control system. On the control box is electrical system.



**Scissor lift is designed and built to lift all kinds of vehicles, All other use are unauthorized. In particular, the lift is not suitable for: washing and respray work, creating raised platforms or lifting personnel, use as a makeshift press for crushing purposes, use as good lift. And not lift the vehicle which weight exceed the maximum weight.**

## SPECIFICATIONS

MODEL	J3.6		
Drive	Electrical hydraulic		
Max lift weight	3500kg		
Sub machine lift weight	3500kg		
Main machine Lift height	2000mm		
Sub machine lift height	460mm		
Platform initial height	350mm		
Main machine platform length	5000mm		
Sub machine platform length	1400mm		
main machine platform width	640mm		
Sub machine platform width	550mm		
main machine Lifting time	≤50S		
main machine lowering time	≤60S		
Sub machine Lifting time	≤20S		
Sub machine lowering time	≤30S		
Overall width	Approximately 2070mm		
Overall length	4500mm		
Overall weight	2300Kg		
power	AC 380 or 230V ± 5% 50Hz		
Hydraulic oil	20L 48# high abrasive hydraulic oil		
temperature	5-40℃		
	30-95%		
Noisy	76db		
Installation height	≤1000M		
Storage temperature	-25-55C		

Chapter 2 TECHNICAL SPECIFICATIONS

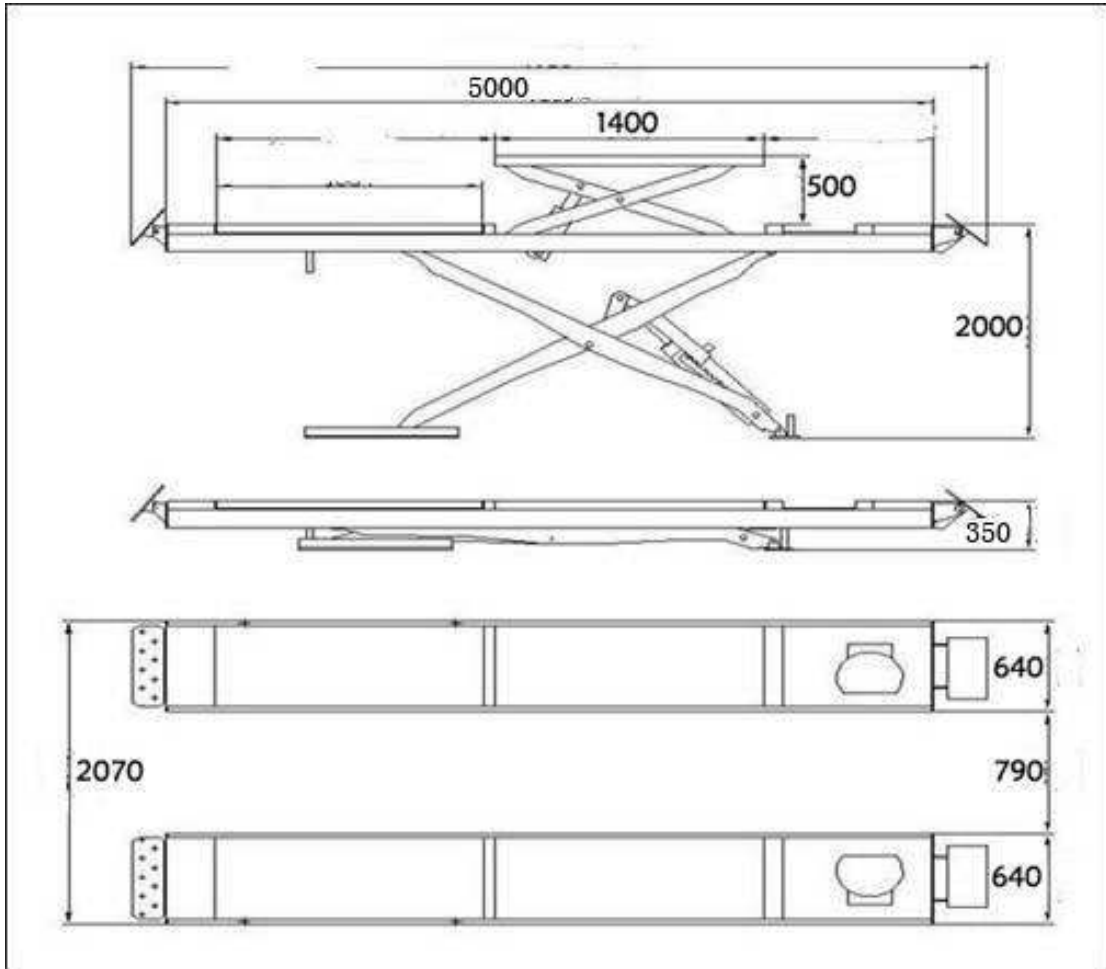

(picture 3)

**MOTOR PUMP:**

Type-----Y90L  
 Power-----2.2Kw  
 Voltage-----AC400V or 230V  
 Ie-----400V:5A  
 -----230V:8.7A  
 Frequency-----50Hz  
 Poles-----4  
 Speed-----1450rpm/min  
 Building shape-----B14  
 Isulation class-----F  
 When connecting the motor refer to

**PUMP:**

Type----- P4.3  
 Model----- teeth pump  
 Dispacement----- 4.3cc/r  
 Transmission: joint type-----  
 Relief valve  
 Continuous working pressure-- 210bar  
 Intermittent working pressure-150-300 bar  
 Oil  
 Inject 20 litters of hydraulic oil into the oil

the enclosed wiring diagrams on the tank  
data plate on the casing.

## Chapter 2 TECHNICAL SPECIFICATIONS

### Installation scheme for lift



To install the lift it is necessary to execute suitable foundations with the following characteristics:

- concrete type 425
- thickness of concrete  $\geq 150$ mm, the leveling of whole length  $\leq 10$ mm
- perfect parallelism between holes.

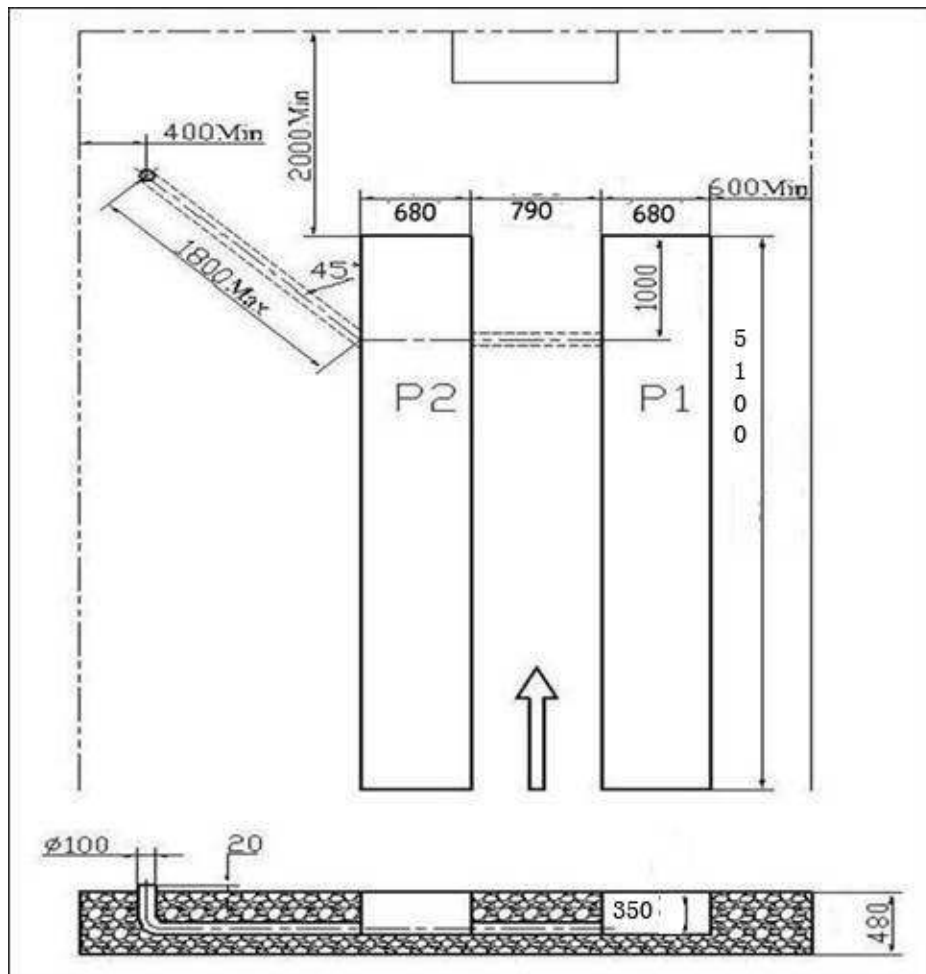

(picture 4)



The thickness and levelling of the base concrete are essential and the levelling adjustment ability of the machine itself cannot be relied upon to excessively.

## Chapter 2 TECHNICAL SPECIFICATIONS

### Types of vehicles suitable for being lifted and overall dimensions

Lift are suitable for virtually all vehicles with total weight of no more than 4000kg or 5500kg

and with dimensions not exceeding the below data.

**Maxim Weight:** J3.6  $\cong$  3500kg

The following diagrams illustrate criteria used to define the operating limits of the lift.

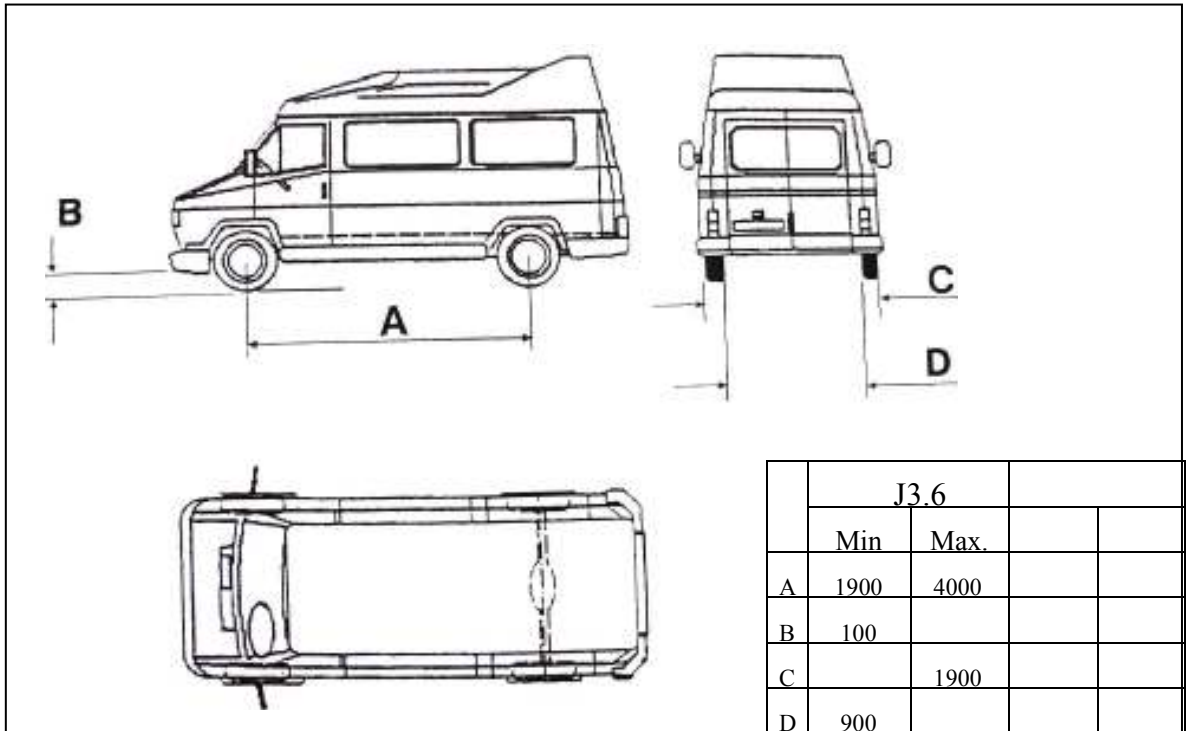

(picture 5)



The lower parts of the vehicle underbody could interfere with structural parts of the lift, take particular parts of the sports-car.

The lift will also handle customized or non-standard vehicles provided they are within the maximum specified carrying capacity.

Also the personnel safety zone must be defined in relation to vehicle with unusual dimensions.

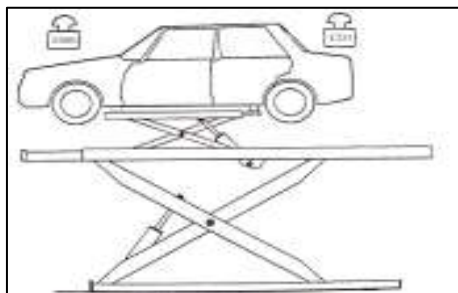

(picture 6)

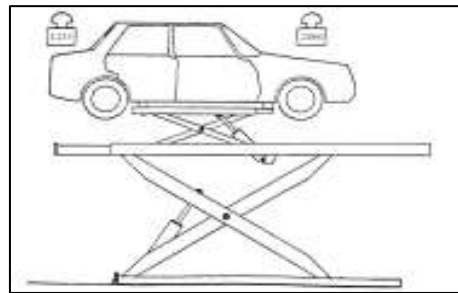

(picture 7)



**safety of the operator or others in case of improper use of the lift is included.**

In the following text there are clear explanations regarding certain situations of risk or danger that may arise during the operation or maintenance of the lift, the safety device installed and the correct use of such systems, residual risks and operative procedures to use ( general specific precautions to eliminate potential hazards).



**Lifts are designed and built to lift vehicles and hold them in the elevated position in an enclosed workshop. All other uses of the lifts are unauthorized. In particular, the lifts are not suitable for:**

- washing and respray work;
- creating raised platforms for personnel or lifting personnel;
- use as a press for crushing purposes;
- use as elevator;
- use as a lift jack for lifting vehicle bodies or changing wheels.



The manufacturer is not liable for any injury to persons or damage to vehicles and other property caused by the incorrect and unauthorized use of the lifts.

During lifting and lowering movements the operator must remain in the control station.

The presence of persons inside the danger zone indicated is strictly prohibited.

During operations persons are admitted to the area beneath the vehicle only when the vehicle is already in the elevated position, when the platforms are stationary, and when the mechanical safety devices are firmly engaged.



**Do not use the lift without protection devices or with the protection devices inhibited.**

**Failure to comply with these regulation can cause serious injury to persons, and irreparable damage to the lift and the vehicle bein lifed.**

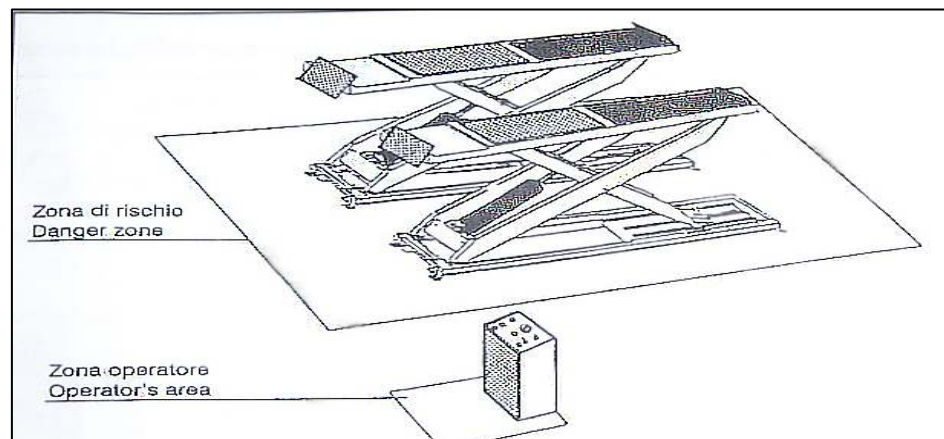

(picture 8)

## GENERAL PRECAUTIONS



The operator and the maintenance fitter are required to observe the prescriptions of safety regulation in force in the country of installation of the lift.

Furthermore, the operator and maintenance fitter must:

- always work in the stations specified and illustrated in this manual;
- never remove or deactivate the guards and mechanical, electrical, or other types of safety devices;
- read the safety notices placed on the machine and the safety information in this manual.

In the manual all safety notices are shown as follows:



**WARNING:** indicates situations and/or types of manoeuvres that are unsafe and can cause minor injury to persons and /or death.



**CAUTION:** indicates situations and/or types of manoeuvres that are unsafe and can cause minor injury to persons and/or damage the lift, the vehicle or other property.



**RISK OF ELECTRIC SHOCK:** a specific safety notice placed on the lift in areas where the risk of electric shock is particularly high.

### Risk and protection devices

We shall now examine the risks that operators or maintenance fitters may be exposed to when the vehicle is standing on the platforms in the raised position, together with the various safety and protection devices adopted by the manufacturer to reduce all such hazards to the minimum:

**For optimal personal safety and safety of vehicles, observe the following regulations:**

- do not enter the safety and safety of vehicles are being lifted.
- switch off the engine of the vehicle, engage a gear and engage the hand brake,
- make sure the vehicle is positioned correctly.
- be sure to lift only approved vehicles, never exceed the specified carrying capacity, maximum height, and projection (vehicle length and width);
- make sure that there are no person on the platforms during up and down movements and during standing.

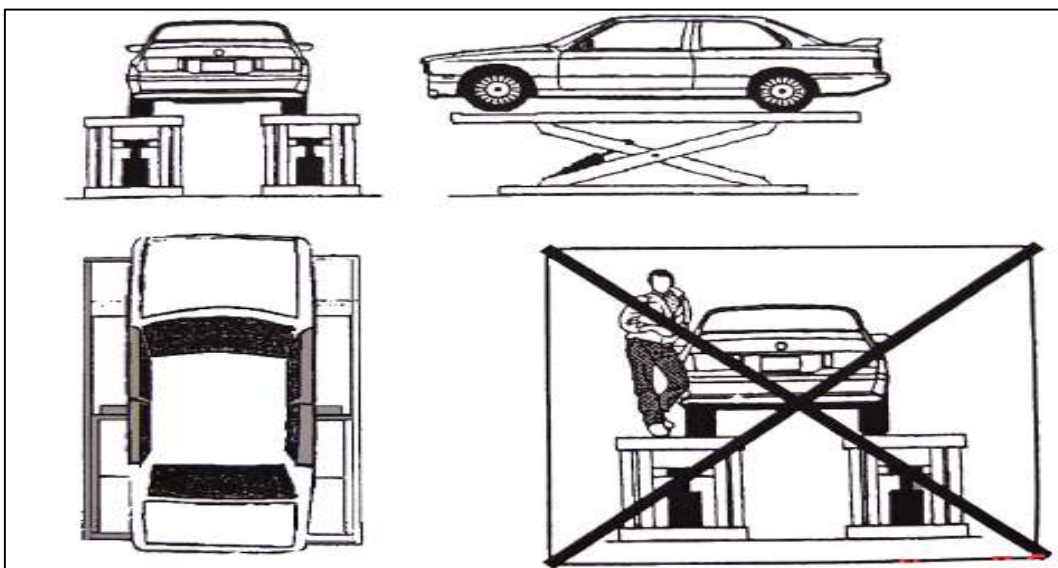

(picture 9)



(picture 10)



(picture 11)



(picture 12)



(picture 13)

### **RISKS FOR PERSONNEL**



This heading illustrates potential risks for the operator, maintenance fitter, or any other person present in the area around the lift, result from incorrect use of the lift.

### **RISK OF CRUSHING**



Possible if the operator controlling the lift is not in the specified position at the control panel.

When the platforms (and vehicle) are lowering the operator must never be partly or completely underneath the movable structure. Always remain in the control zone.

### **RISK OF CRUSHING (PERSONNEL)**



When the platforms and the vehicle are lowering personnel are prohibited from

entering the area beneath the movable parts of the lift. The lift operator must not start the manoeuvre unit if it has been clearly established that there are no person in potentially dangerous positions.

### Chapter 3 SAFETY



#### RISK OF IMPACT

Caused by the parts of the lift or the vehicle that are positioned at head height.

When, due to operational reasons, the lift is stopped at relatively low elevations personnel must be careful to avoid impact with parts of the machine not marked with special colors.

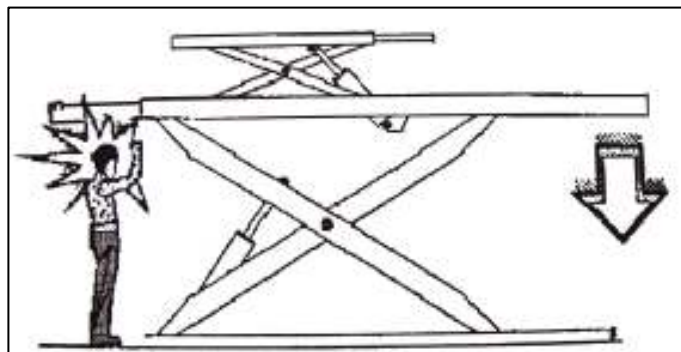

(picture 14)

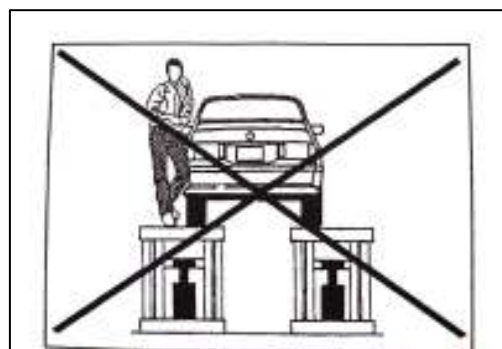

(picture 15)



#### RISK OF VEHICLE MOVING

Caused by operations involving the application of force sufficient to displace the vehicle.

In the case of large or particular heavy vehicles, sudden movement could create an unacceptable overload or uneven loadsharing. Therefore, before lifting the vehicle and during all operations on the vehicle-make sure that it is properly stopped by the hand brake.

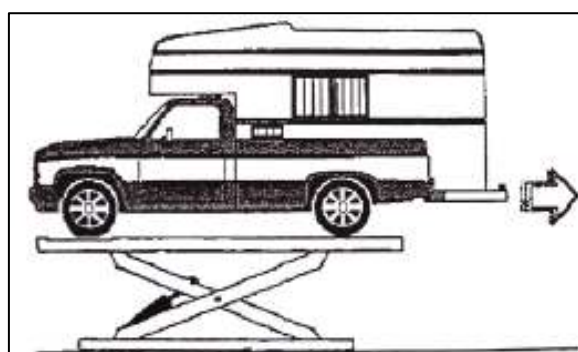

(picture 16)

**Chapter 3 SAFETY****RISK OF VEHICLE FALLING FROM LIFT**

This hazard may arise in the case of incorrect positioning of the vehicle on the platforms, incorrect stopping of the vehicle, or in the case of vehicles of dimensions that are not compatible with the capacity of the lift.

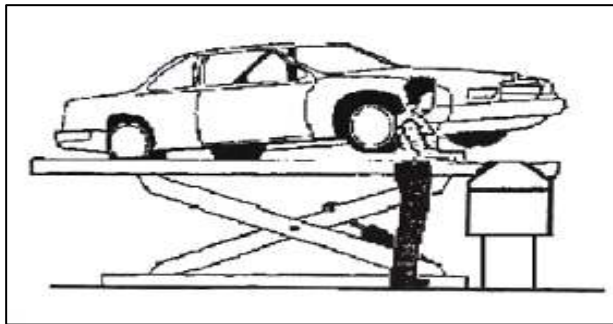

(picture 17)



**Never attempt to perform tests by driving the vehicle while it is on the platforms**  
**Never leave objects in the lowering area of the movable parts of the lift.**

**RISK OF SLIPPINE**

Caused by lubricant contamination of the floor around the lift.

The area beneath and immediately surrounding the lift and also the platforms must be kept clean.

Remove any oil spills immediately.

When the lift is fully down, do not walk over the platforms or the cross-pieces in places that are lubricated with a film of grease for functional requirements.

Reduce the risk of slipping by wearing safety shoes.

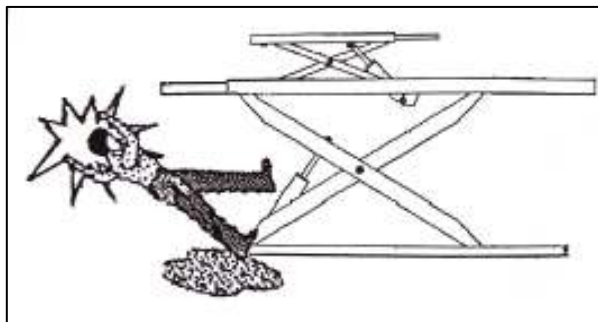

(picture 18)

**RISK OF ELECTRIC SHODK**

Risk of electric shock in areas of the lift housing electrical wiring.

Do not use jets of water, steam solvents or paint next to the lift, and take special care to keep such substances clear of the electrical control panel.

**RISKS RELATED TO IMAPPROPRIATE LIGHTING**

The operator and the maintenance fitter must be able to assure that all the areas of the lift are properly and uniformly illuminate compliance with the laws in force in the place of installation.

**Chapter 3 SAFETY**

How to regulation over pressure valve.1> test pressure at normal load less than standard pressure.2> close the tap after the monomter.3>regulate the over pressure valve to 110% of point 1 pressure (point 5.7.4.1 of EN1493:1998)

**RISK OF COMPONENT FAILURE DURING OPERATION**

The manufacturer has used appropriate materials and construction techniques in relation to the specified use of the machine in order to manufacture a reliable and safe lift. Note however, that the lift must be used in conformity with manufacturer's prescriptions, and the frequency of inspections and maintenance works recommended .

**RISK RELATED TO IMPROPER USE**

Persons are not permitted to stand or sit on the platforms during the lift manoeuvre or when the vehicle is already lifted.

**The handling of safety devices is strictly forbidden.**

**Never exceed the maximum carrying capacity of the lift, make sure the vehicles to be lifted have no load.**

It is therefore essential to adhere scrupulously to all regulations regarding use, maintenance and safety contained in this manual.

**GENERAL RISKS FOR LIFTING OR DESCENT**

The following safety equipments is used to protect over loading or the possibility of engine failure.

Each bottom of oil cylinder is equipped with antiknock and locked valve. When the oil pipe is burst in the circuit of hydraulic pressure, the relevant antiknock and locked valve will work and limit the speediness of platform.



## Chapter 4 INSTALLAION



**Skilled and authorized personnel only should be allowed to perform these operations, follow all instructions shown below carefully, in order to prevent possible damage to the car lift or risk of injury to people. Be sure that the operating area is cleared of people.**

Skilled technicians only, appointed by the same manufacturer or by authorized dealers, are allowed to install the car lift. Serious damage to people and equipment can be caused if this rule is not followed.

### INSTALLATION REQUIREMENTS

The car lift must be installed according to the specified safety distances from walls must be 1000 mm at least, taking into consideration the necessary space to work easily. Further space for the control site and for possible runways in case of emergency is also necessary, the room must be previously arranged for the power supply and pneumatic feed of the car lift. The room must be 4000 mm in height, at least, the car lift can be placed on any floor, as long as it is perfectly level and sufficiently resistant.

-All parts of the machine must be uniformly lit with sufficient light to make sure that the adjustment and maintenance operations specified in the manual can be performed safely, and without areas of shadow, reflected light, glare and avoiding all situations that could give rise to eye fatigue.

-The lighting must be installed in accordance with the laws in force in the place of installation.

-the thickness and leveling of the base concrete are essential

-thickness of concrete  $\geq 150\text{mm}$ , the leveling of whole length  $\leq 10\text{mm}$ .

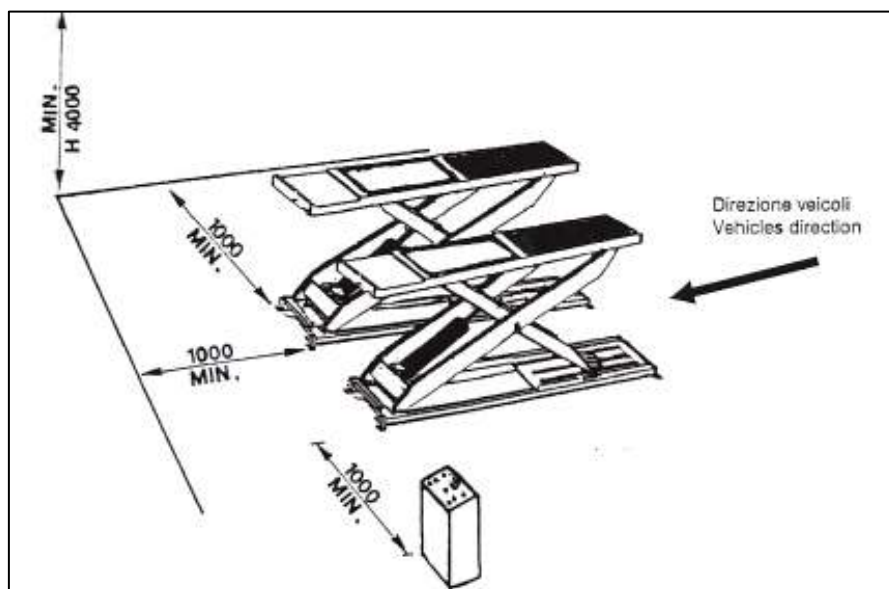

(picture 21)

#### Chapter 4 INSTALLATION

### CROSSBEAM INSTALLATION

- put two transom on the bracket.
- fix the direction of moving vehicle according to the position of the location. Put two beam on the transom, the main beam should located on the left side of the moving vehicle direction, the sub-beam located on the right side, the rolling wheel notch on the beam should inside.
- check two platform and the diagonal of two transom are straight, then put four posts on the side of the transom, and fix the nuts on the roof of the post with steel line, put the safety teeth trough the limit axis, also fix the nuts on the roof of the post.

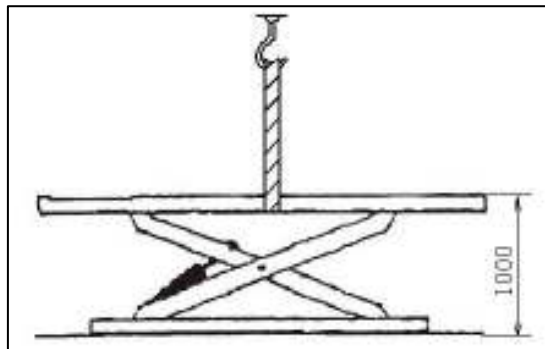

(picture 22)

### ROLLING JACK INSTALLATION

- adjust the distance of the rolling jack, put the rolling jack between the slide track.
- adjust the sub beam to make sure the sliding of the rolling jack.

### LINE CONNECTION

Connect the electrical and oil line according to the electric wiring diagram and oil line connection



**To avoid the unexpected lift closure due to mechanical safety device release insert wooden pieces in the inner part of the base frame.**

**Pay attention not to work under the lift until the hydraulic system has not been completely filled with hydraulic oil.**

**To insert the lift into the recess, sling the lift as described and pay attention not to damage the hoses and electrical cables.**

**Before placing the pneumatic and hydraulic hoses to the control unit, stick adhesive tape on the pipe fittings in order to protect the hoses from dust and impurities which could damage the hydraulic system.**

Perform electric, hydraulic and pneumatic connections, follow carefully the relevant numbering. Regarding the proper connections necessary to make the car lift perfectly working.

#### Chapter 4 INSTALLAION



**Skilled personnel only is allowed to perform the operations shown below.**

-open the control box front cover

-connection of power supply: the connection wires (BVR-3\*2.5mm<sup>2</sup>+2\*1.5mm<sup>2</sup>) for power supply are connected to terminals 1#, 2#, 3#, the zero wire is connected to terminal 0#. The ground wire is connected under the bolt marked ground.

-the electric panel are arranged by the manufacturer for operating at 400V three-phase, therefore if you wish the lift to operated at 230V three-phase, change the connection on the transformer and motor.

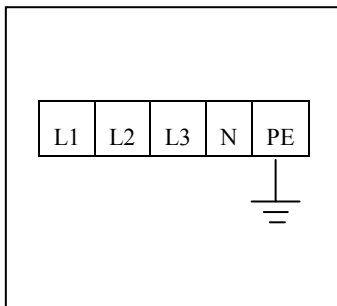

(picture 23)

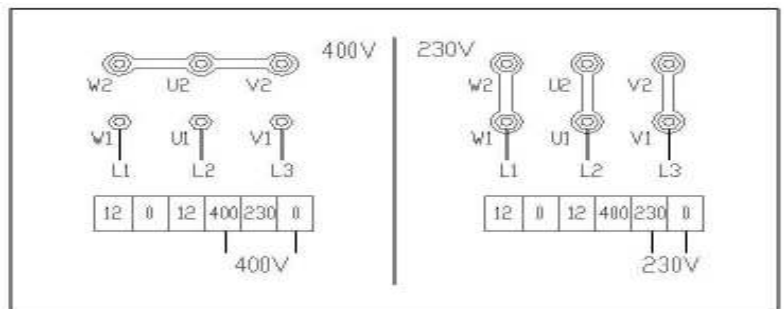

(picture 24)

The limit switch connection (equipped with electrical carriage)

Connect the PE,10# from the control box with metal hoses to the limit switch of electrical rolling jack.



(picture 25)

#### Hydraulic hoses connection

Connect the hydraulic hoses as oil route connection drawing.

#### Electrical carriage oil line connection:

The oil line of electrical carriage from manual selector to oil tank .



(picture 26)

Chapter 4 INSTALLATION



(picture 27)

Chapter 5 ADJUSTMENT

**Add oil and check the order of phase.**

-open the hydraulic oil tank , add 18L of hydraulic oil into the oil tank, the hydraulic oil is provided by the user.



**Make sure the clean of hydraulic oil, prevent any impurity into the oil line, lead the digest of the oil line and no working of the solenoid valve.**

-press the “power” button to turn on power, clicking the “up” button, check whether the motor turns clockwise (looking downward), if not press “power” button, change the phase of the motor.



**When turn on power, there is high voltage in the control box, only authorized person can operate.**



(picture 28)

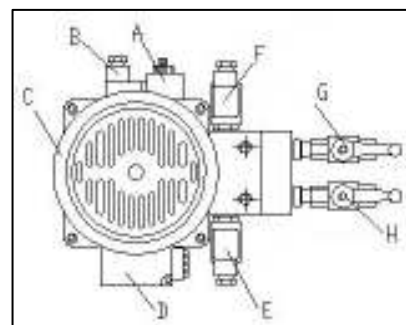

(picture 29)

### Main machine oil make-up adjustment

- 1-Turn the selector switch on the control panel to the “main” position.
- 2-close the oil make up stop valve “G” on the main machine and the oil make up stop valve “H” on the sub machine.
- 3-press “lift” button, and thus the left platform ( looking from machine head direction ) is lifted to about 1000mm.
- 4-press the “lower” button to lower the left platform to the lowest position.

- 5-then lift it up to approximately 1400mm.
- 6-turn the adjustment switch (fix on the side of electrical board) to “ adjust” position.
- 7-open the oil make up stop valve “G” on the main machine. (clockwise)
- 8-press “up” button, and the right platform ( looking from machine head direction ) is lifted to about 1000 mm.
- 9-press “ lower” button. to lower the platform to the lowest position.
- 10-repeat the lifting and lowering process for 8-9 times to vent air automatically.
- 11-then lift the right platform to 1400mm. ( two platforms of the main machine are lifted to the same height ).

#### Chapter 5 ADJUSTMENT

- 12-close the stop valve for make-up oil “G” (anti-clockwise 90), turn adjustment switch to “ work” position, so come into the normal lift mode.
- Check oil leakage of the oil line and air tightness of the air loop.

#### **Sub machine oil make- up adjustment**

- 1-Turn the selector switch on the control panel to the “sub machine” position.
- 2-close the oil make up stop valve “G” on the main machine and the oil make up stop valve “H” on the sub machine.
- 3-press “lift” button, and thus the right platform of the sub machine ( looking from machine head direction ) is lifted to about 300 mm.
- 4-press the “lower” button to lower the right platform of sub machine to the lowest position.
- 5-then lift the right platform of the sub machine up to approximately 400mm.
- 6- turn the adjustment switch (fix on the side of electrical board) to “ adjust” position.
- 7-open the oil make up stop valve “H” on the sub machine. (clockwise)
- 8-press “up” button, and the left platform ( looking from machine head direction ) is lifted to about 300 mm.
- 9-Press “ lower” button to lower the left platform of the sub machine to the lowest position.
- 10-Repeat the lifting and lowering process for 8-9 times to vent air automatically.
- 11-then lift the left platform of sub machine to 400mm. ( two platforms of the main machine are lifted to the same height ).
- 12-close the stop valve for make-up oil “H” (anti-clockwise 90), turn adjustment switch to “ work” position, so come into the normal lift mode.

**Check oil leakage of the oil line and air tightness of the air loop.**

#### **Limit switch of sub machine adjustment**

- turn “selector switch” to “submachine”, press “up button”, and thus the sub machine

platform is lifted to about 450mm, adjust the limit switch

-lower the submachine platform, lift the submachine platform to 450mm, to check the efficiency of the sub machine.

**Limit switch of main machine adjustment**

-turn the “selector switch” to “main machine”, press “up button” and then lift the platform to 1700mm, adjust limit position

-lower the main machine platform, lift main machine platform to the limit position several

Chapter 5 ADJUSTMENT

times to check the efficiency of the limit position of the main machine.



**If the ceiling is lower than 4000mm, it should do the limit adjustment after lift the vehicle.**

**Anchor bolts installation**

-affix the lift to the concrete base with 16 anchor bolts using a percussion drill into 120mm.

-At first, no expansion bolts are installed.



(picture 30)



(picture 31)

**-adjust the parallel of the platform and the distance of two platform**

-lock the machine in one safety teeth

-pad a shim

-adjust the clearance in front and back, and to the left and right,

-fix the anchor bolts (16 bolts) with a percussion electric drill ( percussion drill bit is of 16, drill to 120mm hole and clean the hole.

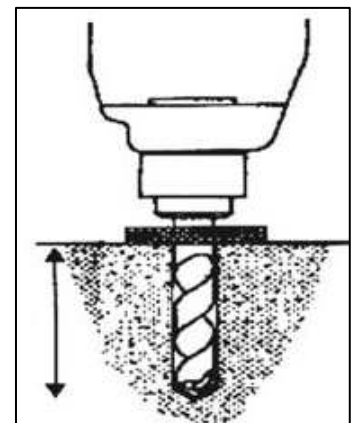

(picture 32)

**Level adjustment.**



**-By using a level bar and the horizontal pipe and adjusting the adjustment screws at tow sides of the base plate.**

-adjust the level of two front turntables and the slide plates on two sides of the base plate, adjust the level of two front turntables and the slide plates on two sides at back, thus keep the levelness of error of the two platform  $\leq 5\text{mm}$ , and keep the height difference between the two platform  $\leq 10\text{mm}$ .

-the gap between the base plate and ground after adjustment must be filled with iron plate or concrete and then tighten the anchor bolts.

#### Chapter 5 ADJUSTMENT

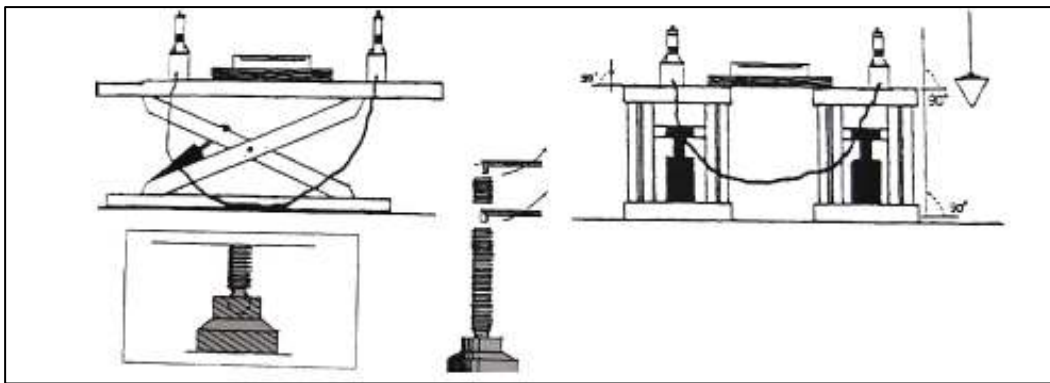

(picture 33)



(picture 34)



(picture 35)

#### No load of main machine test

- turn on the power
- press “up” button, main platform lifted.
- press “down” button, and press insurance hand, the platform is lower.
- press “lower”, four insurance locking.
- check the lift of main machine is placidity, and the locking is secure, check whether the oil line is leakage.



**No person and thing leave under or on the lift.**

## Chapter 6 OPERATION

**-clear obstacles around before operation.**

**-during lifting or lowering, no person is allowed to stand neat the two sides and beneath the machine, and no person is allowed on the two platform.**

**-avoid lifting super heavy vehicles.**

**-when lifting vehicle, the hand brake lever of the vehicle should be pulled, and the slide resistant triangle woods should be used.**

**-pay attention to the synchronization of the lifting and lowering. If any abnormal is found, stop the machine timely, check and remove the trouble.**

**-when locking the main machine, the two platforms should be kept at the same height.**

**-when the equipment is not used for a long time or over night, the machine should be lowered to the lowest position on ground, and remove vehicle, and cut off power supply.**

**Instructions on electric operation:(see the operation panel)**



### **Lifting**

### **picture 36**

Press “ lift” button, the machine will be lifted immediately,

while motor M starts operation and the safety pawl is lifted, because the solenoid air valve DQ is energized and open the air loop ( note: the secondary carriage has no delay of pawl operation.)

Releasing “ lift” button, the machine will stop immediately, while motor M stops operation and the safety pawl falls to the safety teeth bar because the solenoid air valve DQ is energized and air loop is open.

### **Emergency stop**

When the machine have abnormal or car maintenance, push “emergency stop” button and locking, cut off all the operation circuit, other operation can not be work.

### **Oil make-up “adjust” operation ( normal service period)**



after completion of machine installation and adjustment in the application process, the right platform is lower than the left one ( looking from machine head ) because of normal looses or leakage of the hydraulic oil.

**When conducting oil make-up operation, the platforms must not be load.**

#### Chapter 6 OPERATION

- lift the machine platforms to the height of 500mm above the ground.
- then close ( turn right “ the work stop valve” and open the oil make-up stop valve G in control box.
- clicking the “lift button” on control panel, the right platform is lifted alone.
- after the two platforms both have the same height, close the oil make-up stop valve “G”, turn adjustment switch to “work” position.

#### Chapter 7 TROUBLESHOOTING

	Cause and Phenomena	Resolutions
The motor does not run in lifting operation.	① Connection of power supply wires or zero wire is not correct.	Check and correct wire connection.
	② The AC contactor in the circuit of the motor does not pick up.	If the motor operates when forcing the contactor down with an isolation rod, check the control circuit. If the voltage at two ends of the contactor coil is normal, replace the contactor.
	③ The limit switch is not closed.	Short-circuit terminal 10# and 0#, which are connected with the limit switch, and if the trouble disappears, check the limit switch, wires and adjust or replace the limit switch.
In lifting operation, the motor runs, but there is no lifting movement.	① The motor turns reverse.	Change the phases of the power supply wires.
	② Lifting with light load is normal but no lifting with heavy load.	The set safe pressure of the over-flow valve may be increased by turning the set knob right ward slightly. The spool of the lowering solenoid valve is stuck by dirt. Clean the spool.
	③ The amount of hydraulic oil is not enough.	Add hydraulic oil.
	④ The “operation stop valve” is not open.	Turn right and open the “Operation stop valve and supply hydraulic oil to main oil cylinder.
When press “Lower” button, the machine is not lowered.	① The safety pawl are not released form the safety teeth.	First lift a little and then lowering.
	② The safety pawl is not lifted.	The air pressure is not enough or the safety pawl is stuck.
	③ The solenoid air valve does not work.	If the solenoid air valve is energized, but does not open the air loop, check or replace the solenoid air valve.
	④ The lowering solenoid valve is energized but does not work.	Check the plug and coil of the lowering solenoid valve and check the right turn tightness of its end copper nut and so on.
	⑤ The hydraulic oil has too high viscosity or frozen, deteriorated (in Winter).	Replace with 20# hydraulic oil in accordance with the instruction book.
The machine lowers extremely slowly under normal loads.	The “antiknock valve” for preventing oil pipe burst is blocked.	Remove or close air supply pipe and thus lock the safety pawl of the machine without lifting of the safety pawl. Remove the “antiknock valve” from the oil supply hole at the bottom of the oil cylinder, and clean the “antiknock valve”.
The right and left platforms are not synchronous and not in the same height.	① The air in the oil cylinder is not vent completely.	Refer to “VII. Oil Make-up ‘Adjust’ Operation”.
	② Oil leakage on oil pipe or at its connections.	Tighten oil pipe connections or replace oil seals and then make-up oil and adjust levelness.
	③ The “oil make-up stop valve” can not be closed tightly and almost make-up oil and adjust every day.	Replace oil make-up stop valve, and then make-up oil and adjust.
Noisy lifting and lowering.	① Lubrication is not enough.	Lubricate all hinges and motion parts (including piston rod) with machine oil.
	② The base or the machine is twisted.	Adjust again the levelness of the machine, and fill or pad the base.

**HYDRAULIC SYSTEM**

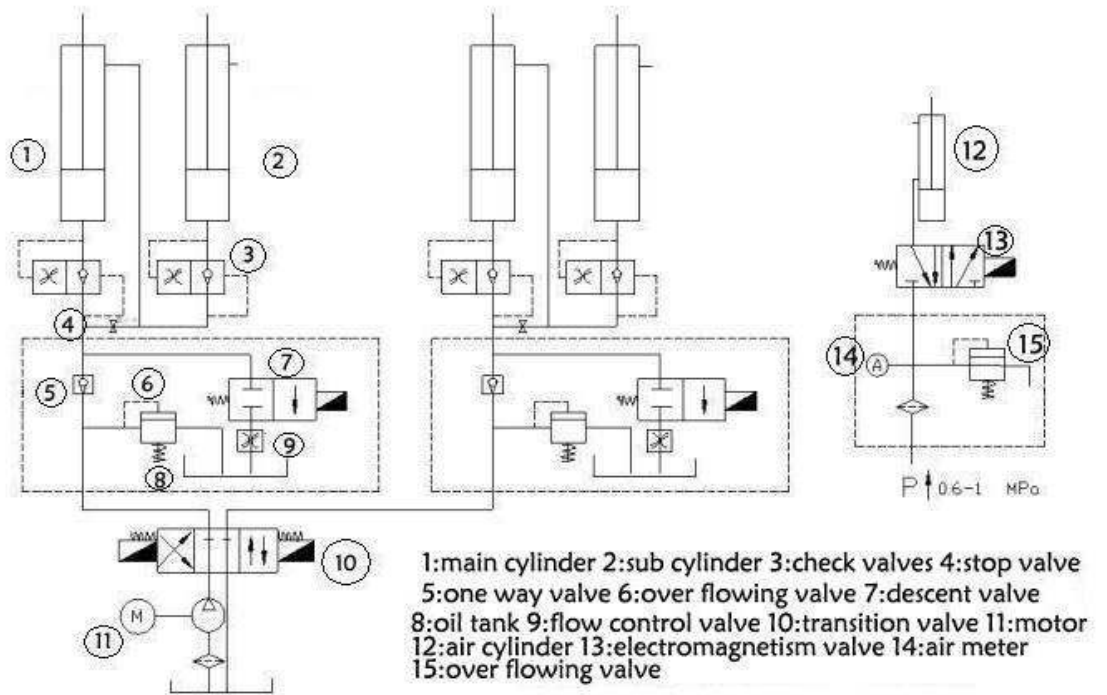

## OIL CONNECTION

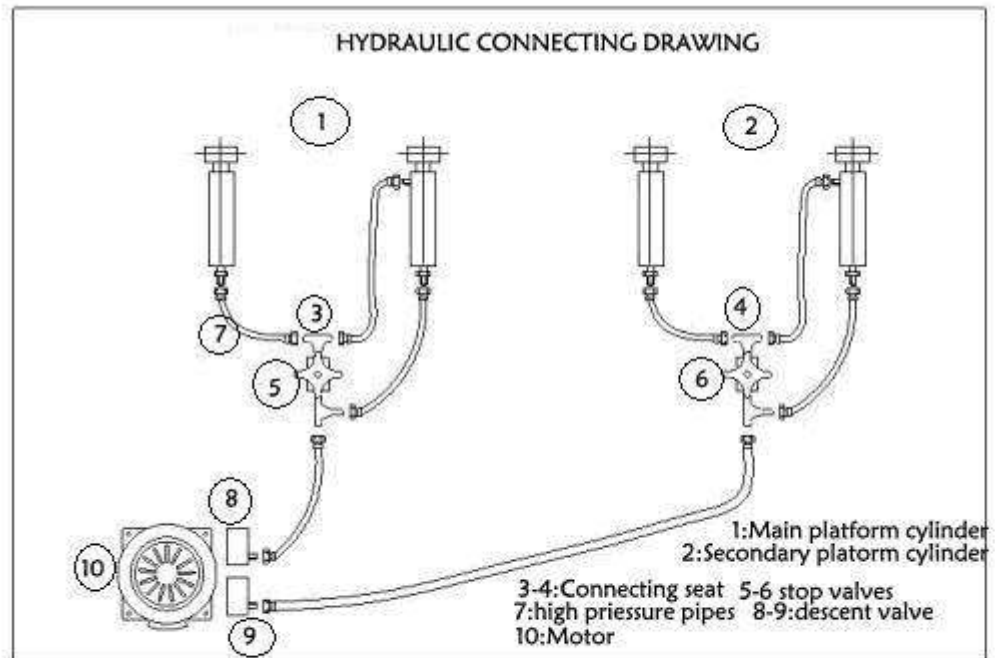

## Electrical Diagram

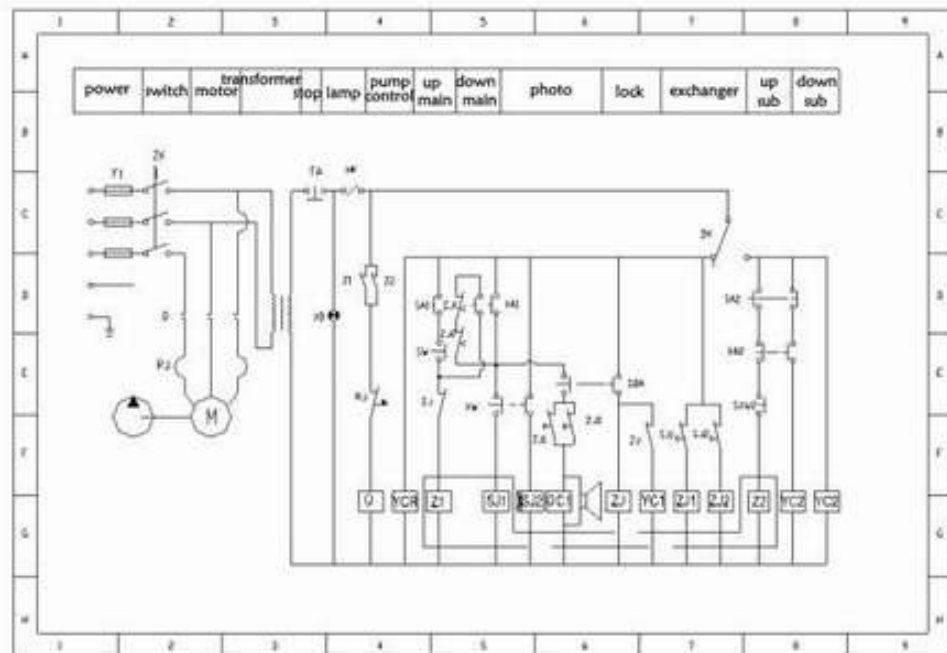

## Electrical components list for model J 3.6 lift

1. F1 fuse 10A
2. F2 fuse 4A
3. ZK power switch
4. Q Contactor
5. M motor
6. B Transformer
7. TA urgent stop
8. HK switch
9. SA up button
10. XA : down button

EXPLODE PICUTURES

